

Tstat6

**Descriptions**

This full-featured CPU based thermostat is designed for small cooling and heating air handling systems in residential and commercial facilities. The unit provides features which eclipse standard mechanical thermostats at a price that fits conventional HVAC projects.

**Highlights:**

- Tight control of 0.5°C provides comfortable indoor environment.
- High impact plastic enclosure provides durability in commercial environments.
- Customizable sequence of operation table (FCU with modulating or on/off valve, single or 3-speed fan, pressure independent VAV, stage sequencer...)



**Technical Data**

<b>TSTAT6</b> .....	5 relays x 2amps @24V, 7 analog inputs, 2 analog outputs (10V @100ma)
Operating temperature.....	-30-70°C(-22~158°F)
Supply voltage.....	12~24VAC/DC ±20%, 50-60Hz
Power consumption.....	100mA at 12VDC
Relay contacts rating.....	2A @ 24VDC, 0.5A @ 125VAC UL File No.: E43149 CSA File No.: LR26550
Ambient humidity.....	10-90 %Rh
Operating Environment.....	0 ~ 99% humidity non condensing
Plastic Housing.....	Flammability rating UL 94V0 file E194560
Enclosure rating.....	IP31
Temperature sensor.....	10K thermistor ±0.5°C
Colour.....	White/Off-white
Weight .....	200g

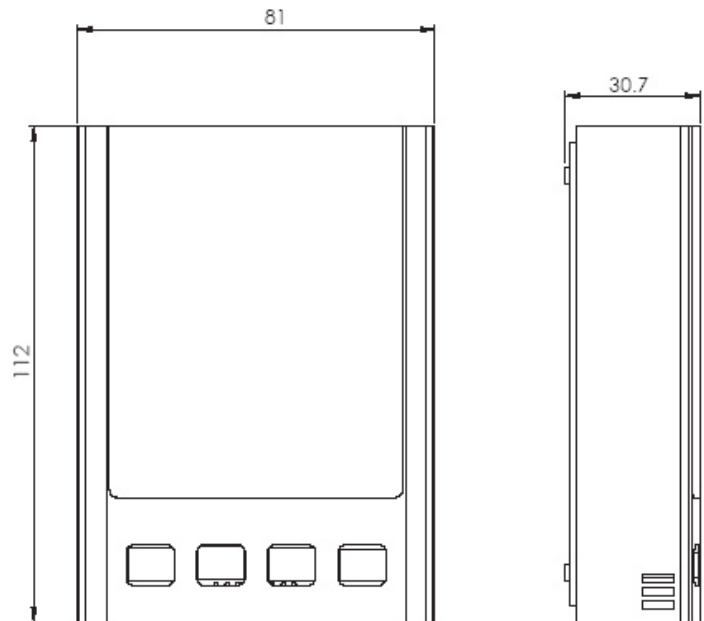

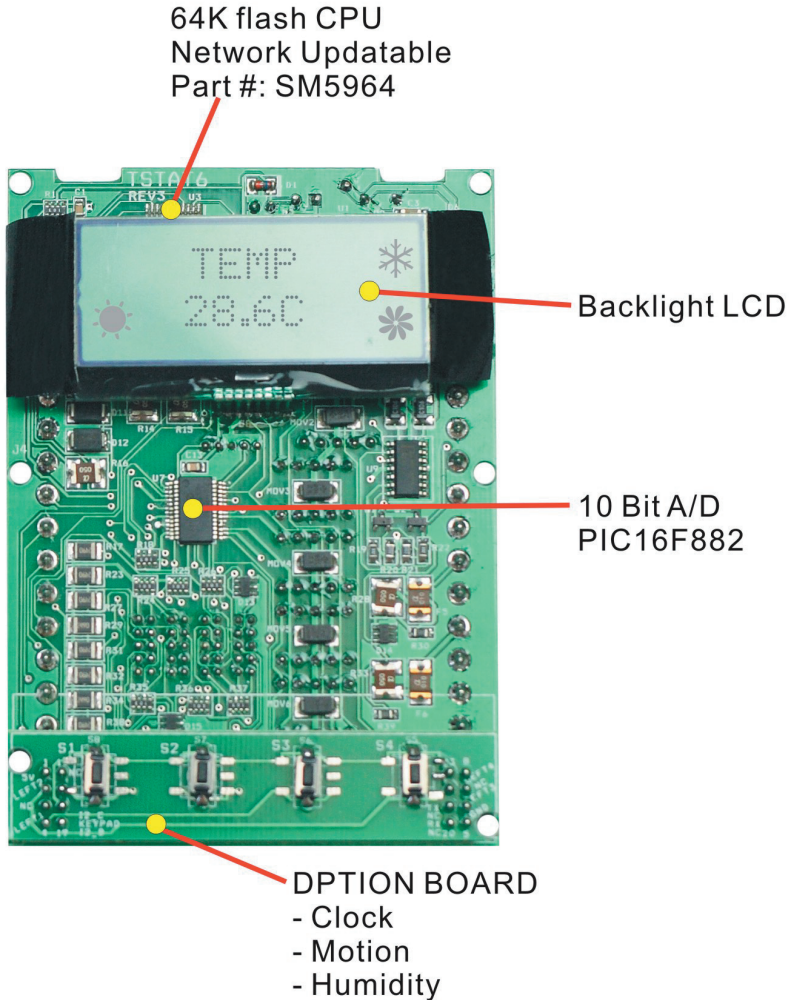
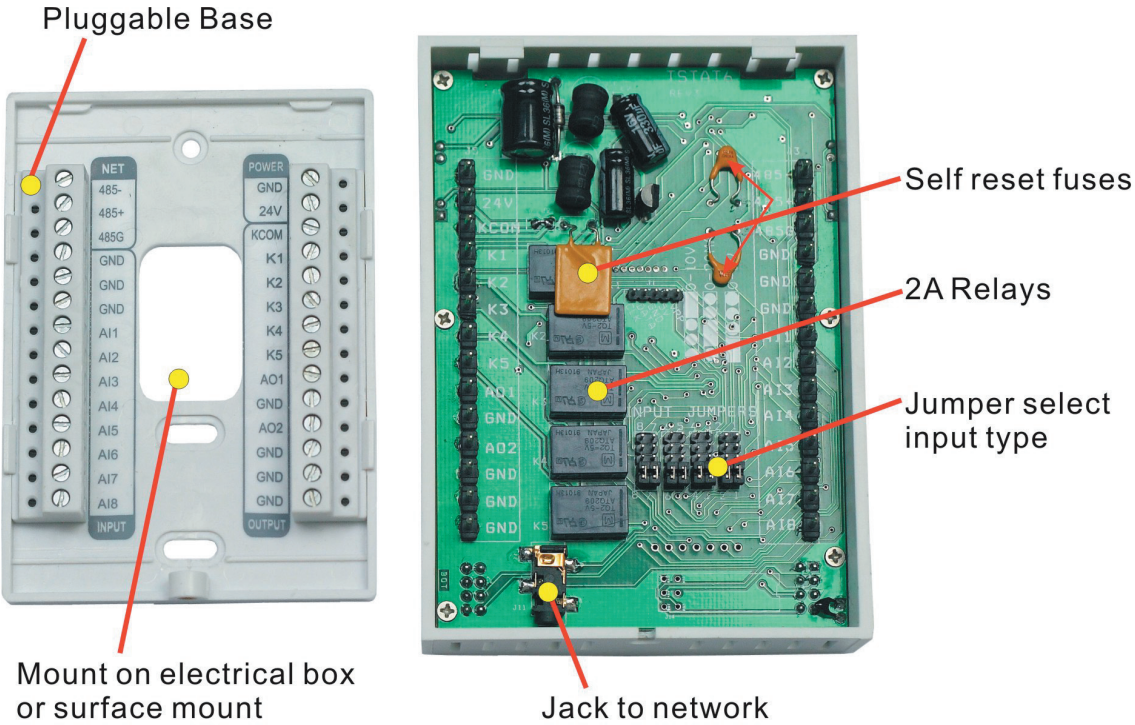

Jumper Settings

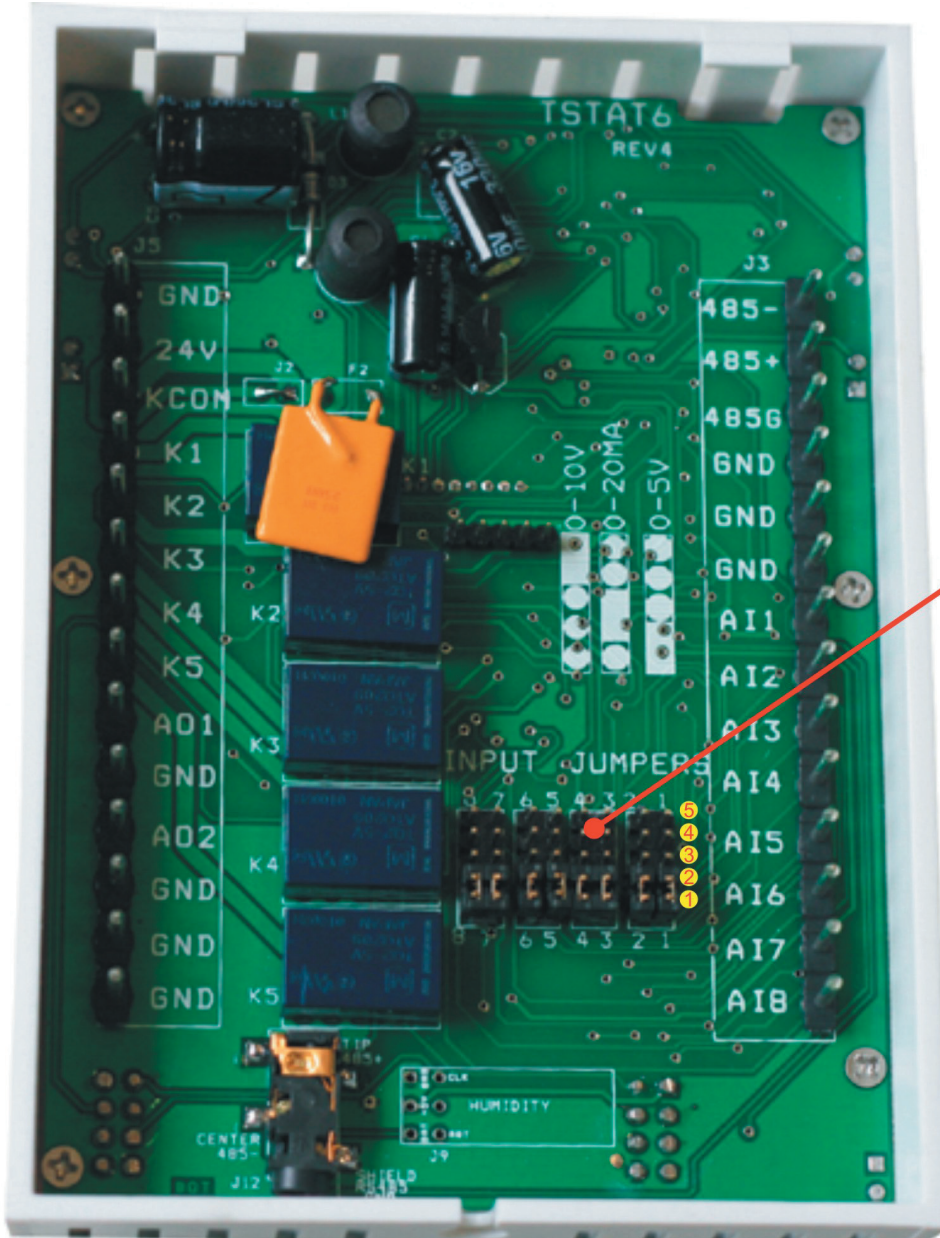

Jumpers:

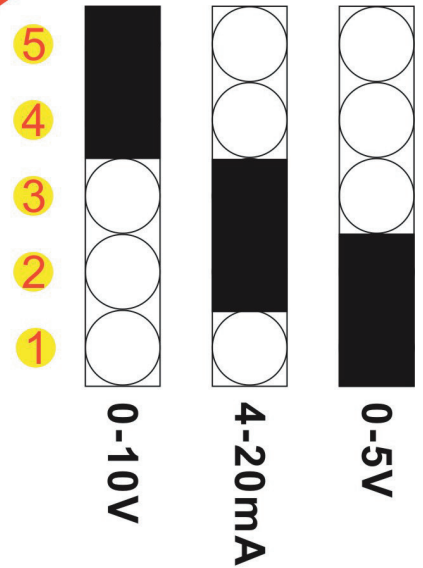

**Register of Tstat6**

Address	Bytes	Register and Description
0-3	4	Serial Number - 4 byte value. Read-only
4-5	2	Software Version – 2 byte value. Read-only
6	1	ADDRESS. Modbus device address
7	1	Product Model. This is a read-only register that is used by the microcontroller to determine the product
8	1	Hardware Revision. This is a read-only register that is used by the microcontroller to determine the hardware rev
9	1	PIC firmware version
10	1	PLUG_N_PLAY_ADDRESS, 'plug n play' address, used by the network master to resolve address conflicts. See VC code for algorithms
15	1	Base address selection.0 = Protocol address,1 = PLC address.
16	1	Firmware Update Register, used to show the status of firmware updates. Writing 143 to register 16 - resets the unit to latest factory defaults.Writing 159 to register 16 - makes the current configuration the new factory default.
17,18,19		Spare
20	2	Hardware Options Register, starting with LSB: Bit0=Clock present or not, Bit1 = Humidity present or not, Bit2 = CO2 Sensor, Bit3=CO sensor, Bit4 = Motion Sensor
21-100		Blank, for future use
101	2	TEMPERATURE reading in DegC or F from the sensor used in the control loop PI1 which is configured in register 111. This can be the internal sensor, external, or an average of the two. Writing a temperature value to this register will calibrate the currently selected sensor by adjusting the associated calibration register. If average is selected then you cannot write to this register.
102	2	COOLING_VALVE, a number from 0-1000 representing 0% (closed) to 100% (open). When Range = On/Off mode, On=1000, Off=0.
103	2	HEATING_VALVE, a number from 0-1000 representing 0% (closed) to 100% (open)
104	2	PID1, current PI calculation for PID number 1 (PID2 is in register 240)
105		NOT USED FOR REV 25
106	1	COOL_HEAT_MODE, heating or cooling mode. 0=none, 1=cooling, 2=heating.
107	1	MODE_OPERATION, heating or cooling state: 0-7=coasting, cooling 1,2,3, heating 1,2,3
108	1	DIGITAL_OUTPUT_STATE, bit 0 thru 4 = relay 1 thru 5.
109	2	CALIBRATION, this is the calibration factor for the internal sensor, normally maintained by the tstat.
110	2	CALIBRATION_EXTERNAL, this is the calibration factor for the external sensor, normally Maintained by the tstat.
111	1	TEMP_SELECT, Sensor to be used for the PID calculations, 1= external sensor analog input 1, 2 = internal thermistor, 3 = average the internal thermistor and analog input1
112	1	DAC_OFFSET, Calibration data for the 0-10VDC signal, internal variable maintained by tstat
113	1	NOT USED FOR REV 25
114	1	PTERM, proportional term for PI calculation
115	1	ITERM, integral term for PI calculation
116	1	NOT USED FOR REV 25
117	1	NOT USED FOR REV 25
118	1	SEQUENCE, 0 = internal test sequence, ooutputs slowly cycle on/off or ramp up & down. 1 = normal, operation according to the output tables.
119	1	COOLING_DEADBAND, offset from setpoint for cooling to begin. Units of 0.1 deg.
120	1	HEATING_DEADBAND, offset from setpoint for heating to begin. Units of 0.1 deg.
121	1	DEGC_OR_F, engineering units, Deg C = 0, Deg F = 1
122	1	FAN, number of fan speeds. Single speed = 1 up to three speed fan = 3
123	1	NIGHT_HEATING_DEADBAND, heating deadband in the night time or OFF mode. Units of 1 deg.
124	1	NIGHT_COOLING_DEADBAND, cooling deadband for the night (OFF) mode. Units of 1 deg.
125	1	NIGHT HEAT/COOL SETPOINTS, 0 = office (absolute setpoints, 1 = Hotel or Residential, deadband type offsets
126	1	POWERUP_SETPOINT, setpoint on power up
127	1	POWERUP_MODE, mode of operation on power up. 0 = power off, 1 = power up in on mode, 2 = last value (default), 3 = auto mode.
128	1	KEYPAD_SELECT, variable to select various keypad arrangements. Refer to PAd description in Table 1: Advanced Menu Items  Number of buttons on the keypad: The keypad can have up to six buttons. The setting is not normally adjusted in the field. Care should be taken to coordinate with the settings in register 106, the Heat / Cool changeover parameter 128=0, two buttons, for adjusting the setpoint. 128=1, 4 buttons, lower pair for the mode and upper pair for the setpoint. 128=2, 6 button keypad, with heat cool manual selection. Lower pair for the mode, next pair for the setpoint and upper pair for the heat or cool mode. 128=3, 6 button keypad, with separate heating and cooling setpoints. Lower pair for the mode, next pair for the cooling setpoint and uppermost pair for the heating setpoint.

Address	Bytes	Register and Description
129	1	AUTO_ONLY , enables or disables manual mode. 0 = Manual Fan Modes 1-x Allowed (depending on R122 value, 1 = Auto Mode Only, 2 = DDC mode,the user can not change setpoint and fan speed from keypad.
130	1	NOT USED FOR REV 25
131	1	MAX_SETPOINT, Setpoint high, the highest setpoint a user will be able to set from the keypad.
132	1	MIN_SETPOINT, Setpoint Low, the lowest setpoint a user will be able to set from the keypad.
133	1	SPECIAL_MENU_LOCK, Special menu lockout via keypad, serial port only, 0=Full Menu, 1=Menu Disabled, 2=User Menu, 3 = The user need adjust setpoint in menu mode, 4 = Part menu
134	1	Write 1 to register 134 - resets the unit to latest factory defaults. (same as writing Writing 143 to register 16)
135	1	COOLING_SETPOINT, current pid setpoint - limits are set by the max and min setpoints
136	1	Heating setpoint,current heating setpoint - limits are set by the max and min setpoints
137	1	FAN_SPEED, current operating fan speed
		Relay Output Tables (bit0 = relay1, bit1 = relay2, bit2 = relay3, bit3 = relay4, bit4 = relay5)
		Fan0 table is for the off state. Fan1, Fan2, and Fan3 are for the manual states. Fan4 is for the Auto state. These states are controlled by the user.
		The mode of operation (coasting, cooling, heating) is determined by the PID parameter.
138	1	FAN0_OPERATION_TABLE_COAST
139	1	FAN0_OPERATION_TABLE_COOL1
140	1	FAN0_OPERATION_TABLE_COOL2
141	1	FAN0_OPERATION_TABLE_COOL3
142	1	FAN0_OPERATION_TABLE_HEAT1
143	1	FAN0_OPERATION_TABLE_HEAT2
144	1	FAN0_OPERATION_TABLE_HEAT3
145	1	FAN1_OPERATION_TABLE_COAST
146	1	FAN1_OPERATION_TABLE_COOL1
147	1	FAN1_OPERATION_TABLE_COOL2
148	1	FAN1_OPERATION_TABLE_COOL3
149	1	FAN1_OPERATION_TABLE_HEAT1
150	1	FAN1_OPERATION_TABLE_HEAT2
151	1	FAN1_OPERATION_TABLE_HEAT3
152	1	FAN2_OPERATION_TABLE_COAST
153	1	FAN2_OPERATION_TABLE_COOL1
154	1	FAN2_OPERATION_TABLE_COOL2
155	1	FAN2_OPERATION_TABLE_COOL3
156	1	FAN2_OPERATION_TABLE_HEAT1
157	1	FAN2_OPERATION_TABLE_HEAT2
158	1	FAN2_OPERATION_TABLE_HEAT3
159	1	FAN3_OPERATION_TABLE_COAST
160	1	FAN3_OPERATION_TABLE_COOL1
161	1	FAN3_OPERATION_TABLE_COOL2
162	1	FAN3_OPERATION_TABLE_COOL3
163	1	FAN3_OPERATION_TABLE_HEAT1
164	1	FAN3_OPERATION_TABLE_HEAT2
165		FAN3_OPERATION_TABLE_HEAT3

Address	Bytes	Register and Description
166	1	FANAUT_OPERATION_TABLE_COAST
167	1	FANAUT_OPERATION_TABLE_COOL1
168	1	FANAUT_OPERATION_TABLE_COOL2
169	1	FANAUT_OPERATION_TABLE_COOL3
170	1	FANAUT_OPERATION_TABLE_HEAT1
171	1	FANAUT_OPERATION_TABLE_HEAT2
172	1	FANAUT_OPERATION_TABLE_HEAT3
		day
173	1	VALVE_OPER_TABLE_COAST, Analog output state for each of the 7 modes of operation
174	1	VALVE_OPER_TABLE_COOLING1
175	1	VALVE_OPER_TABLE_COOLING2
176	1	VALVE_OPER_TABLE_COOLING3
177	1	VALVE_OPER_TABLE_HEATING1
178	1	VALVE_OPER_TABLE_HEATING2
179	1	VALVE_OPER_TABLE_HEATING3
180	2	Analog Input 1, Filtered and calibrated value for analog input 1
181	2	Analog Input 2, Filtered and calibrated value for analog input 2
182	1	Night heating setpoint
183	1	Night cooling setpoint
184	1	Info Byte, this register contains info about the state of the tstat.
		Bit 0 is read/write and shows the occupancy mode. Bit 0 = 0 means unoccupied. Bit 0 = 1 means occupied.
		Bit 1 is read only and shows the reset state. Bit 1 = 0 means hardware restart. Bit 1 = 1 means software restart.
		Bit 2 is read/write and is the reset prevention bit. Bit 2 = 0 means the tstat will automatically reset after certain registers are changed. Bit 2 = 1 prevents this reset. Changing this bit from 1 to 0 will trigger a reset.
		Bit 3 is the state of the digital input. Bit 3 = 1 means logic high. Bit 3 = 0 means logic low.
		Bit 4: Reserved, used for some non standard occupancy sensor logic
		Bit5 0=no delay on modbus reply, 1= 10ms delay before send for slower PLC's to switch from TX to RX
		Bit7, RS485/wireless communications mode: The normal communications method is a bus topology using RS485 which uses a 'transmit enable' or TX_EN line on the RS485 hardware whenever transmission from the thermostat to the bus takes place. For wireless devices this is typically taken care of by the radio module itself so it is not needed. Default = 0, When bit7 is 0, the RS485 chip, TX_EN line is used for normal RS485 bus communications. When bit7 is 1, the TX_EN line is not used, allowing the radio module to communicate one-to-one with the Tstat
185	1	Bau - Baudrate, 0=9600, 1=19.2kbaud
186	1	Ou1 - Output1 Scale - 0=On/Off, 1=0-10V, 2=0-5V, 3=2-10V, 4= 10-0V
187	1	Ou2 - Output2 Scale - 0=On/Off, 1=0-10V, 2=0-5V, 3=2-10V, 4= 10-0V
188	1	AI1 – Analog input 1 range 0=10-bit raw data, 1=10K thermistor, 2=0-100%, 3=on/off, 4=custom
189	1	AI2 – Analog input 2 range 0=10-bit raw data, 1=10K thermistor, 2=0-100%, 3=on/off, 4=custom
190	1	dl1 – Digital input 1 range 0 = ON/OFF.
191	1	OUTPUT1_DELAY_OFF_TO_ON – delay time for output1 going from OFF to ON (sec)
192	1	OUTPUT2_DELAY_OFF_TO_ON – delay time for output2 going from OFF to ON (sec)
193	1	OUTPUT3_DELAY_OFF_TO_ON – delay time for output3 going from OFF to ON (sec)
194	1	OUTPUT4_DELAY_OFF_TO_ON – delay time for output4 going from OFF to ON (sec)
195	1	OUTPUT5_DELAY_OFF_TO_ON – delay time for output5 going from OFF to ON (sec)
196	1	OUTPUT1_DELAY_ON_TO_OFF – delay time for output1 going from OFF to ON (sec)
197	1	OUTPUT2_DELAY_ON_TO_OFF – delay time for output2 going from OFF to ON (sec)
198	1	OUTPUT3_DELAY_ON_TO_OFF – delay time for output3 going from OFF to ON (sec)

Address	Bytes	Register and Description
199	1	OUTPUT4_DELAY_ON_TO_OFF – delay time for output4 going from OFF to ON (sec)
200	1	OUTPUT5_DELAY_ON_TO_OFF – delay time for output5 going from OFF to ON (sec)
201	1	MODBUS_CYCLING_DELAY – delay time (in minutes) for switching out of heating or cooling and then back in.
202	1	MODBUS_CHANGOVER_DELAY – delay time (in minutes) for switching from cooling into heating or vice versa.
203	1	dIS – Display. This sets the display to either room temperature or setpoint. 0 = room temp, 1 = setpoint, 2 = Blank Display,3 = PID2 value,4 = PID2 setpoint, 5 = set segment code by manually, 6 = Display sleep
		LED TABLE Determines what activates the LEDs
204	1	LED1 (top left to bottom right)
205	1	LED2
206	1	LED3
207	1	LED4
208	1	LED5
209	1	LED6
210	1	LED7
211	1	Unoccupied Override Timer, Ort. 0=disabled, >0=number of minutes manual override is allowed
212	1	OVERRIDE_TIMER_DOWN_COUNT - Number of minutes remaining on the timer when unoccupied override timer is in effect.
213	1	Temperature sensor filter, FIL, weighted average of stored value to new raw value
214	1	Heating cooling mode configuration, HC, 0=PID, 1=Keypad, 2=Digital_in1, 3=Digital_in1, 4=Analog_in1, 5=Analog_in2
215	2	Internal Temperature Sensor IC - Internal temp chip, not used in the current hardware
216	2	Internal Thermistor Sensor - Shows the filtered, calibrated value of the internal thermistor sensor
217	2	Calibration for the internal thermistor - internally managed offset for the internal temp sensor value
218	2	Calibration for analog input2 - can write here or write to the analog input and this will be calculated automatically
219	2	Lookup Table 1 - 0.0V value Sensor value that corresponds to 0.0V
220	2	Lookup Table 1 - 0.5V value Sensor value that corresponds to 0.5V
221	2	Lookup Table 1 - 1.0V value Sensor value that corresponds to 1.0V
222	2	Lookup Table 1 - 1.5V value Sensor value that corresponds to 1.5V
223	2	Lookup Table 1 - 2.0V value Sensor value that corresponds to 2.0V
224	2	Lookup Table 1 - 2.5V value Sensor value that corresponds to 2.5V
225	2	Lookup Table 1 - 3.0V value Sensor value that corresponds to 3.0V
226	2	Lookup Table 1 - 3.5V value Sensor value that corresponds to 3.5V
227	2	Lookup Table 1 - 4.0V value Sensor value that corresponds to 4.0V
228	2	Lookup Table 1 - 4.5V value Sensor value that corresponds to 4.5V
229	2	Lookup Table 1 - 5.0V value Sensor value that corresponds to 5.0V
230	2	Lookup Table 2 - 0.0V value Sensor value that corresponds to 0.0V
231	2	Lookup Table 2 - 0.5V value Sensor value that corresponds to 0.5V
232	2	Lookup Table 2 - 1.0V value Sensor value that corresponds to 1.0V
233	2	Lookup Table 2 - 1.5V value Sensor value that corresponds to 1.5V
234	2	Lookup Table 2 - 2.0V value Sensor value that corresponds to 2.0V
235	2	Lookup Table 2 - 2.5V value Sensor value that corresponds to 2.5V
236	2	Lookup Table 2 - 3.0V value Sensor value that corresponds to 3.0V
237	2	Lookup Table 2 - 3.5V value Sensor value that corresponds to 3.5V
238	2	Lookup Table 2 - 4.0V value Sensor value that corresponds to 4.0V
239	2	Lookup Table 2 - 4.5V value Sensor value that corresponds to 4.5V
240	2	Lookup Table 2 - 5.0V value Sensor value that corresponds to 5.0V

Address	Bytes	Register and Description
241	2	Universal PID input select, 0=none, 1=analog_in1, 2=analog_in2
242	2	Universal PID upper deadband
243	2	Universal PID lower deadband
244	2	Universal PID pterm
245	2	Universal PID iterm
246	2	Universal PID setpoint
247	1	Output 1 PID Control 0 = PID1, can assign each output to either PID1 or 2, the max or the min of the two PIDS
248	1	Output 2 PID Control 1 = PID2
249	1	Output 3 PID Control 2 = Maximum of PID1 and PID2
250	1	Output 4 PID Control 3 = Minimum of PID1 and PID2
251	1	Output 5 PID Control
252	1	Output 6 PID Control
253	1	Output 7 PID Control
254	1	PID2 Output table- Coasting
255	1	PID2 Output table- Cooling1
256	1	PID2 Output table- Cooling2
257	1	PID2 Output table- Cooling3
258	1	PID2 Output - Heating1
259	1	PID2 Output - Heating2
260	1	PID2 Output - Heating3
		Analog Output Tables (bit0,1=analog out1, bit2,3=analog out2, 00=0%, 01=0-100%, 11=100%)
261	1	PID2 Valve Output - Coasting
262	1	Universal PID Valve Output - Cooling1
263	1	Universal PID Valve Output - Cooling2
264	1	Universal PID Valve Output - Cooling3
265	1	Universal PID Valve Output - Heating1
266	1	Universal PID Valve Output - Heating2
267	1	Universal PID Valve Output - Heating3
268	1	Number of Heating Stages in Universal Table-(Maximum # of total heating and cooling states is 6)
269	1	Number of Cooling Stages in Universal Table-(Maximum # of total heating and cooling states is 6)
270	1	PID2, the current value of PID number 2
271	2	PID1 Units High byte - Upper 2 bytes of the PID1 units in ASCII
272	2	PID1 Units Low byte - Lower 2 bytes of the PID1 units in ASCII
273	2	PID2 Units High byte - Upper 2 bytes of the PID2 units in ASCII
274	2	PID2 Units Low byte - Lower 2 bytes of the PID2 units in ASCII
275	2	PID2 Unoccupied (OFF) Setpoint
276	1	Number of Heating Stages in Original Table - (Maximum # of total heating and cooling states is 6)
277	1	Number of Cooling Stages in Original Table - (Maximum # of total heating and cooling states is 6)
278	1	PID2 heating or cooling state derived from PID2 register 240, 0=coasting, 1=cooling1, 2=cooling2, 3=cooling3, 4=heating1, 5=heating2, 6=heating3, 14=cooling4, 15=cooling5, 16=cooling6, 17=heating4, 18=heating5, 19=heating6.
279	1	Valve travel time. The time of the valve travel from one end to another end. The units is second.
280	1	Determine the output1 mode. Output1 always is ON/OFF mode
281	1	Determine the output2 mode. Output2 always is ON/OFF mode

Address	Bytes	Register and Description
282	1	Determine the output3 mode. Output3 always is ON/OFF mode
283	1	Determine the output4 mode. 0, ON/OFF mode; 1, floating valve for cooling; 2, lighting control; 3, PWM
284	1	Determine the output5 mode. 0, ON/OFF mode; 1, floating valve for heating; 2, lighting control; 3, PWM
285	1	Valve percent. Show the valve opened how much percent. READ ONLY
		Interlock for each output, analog and digital output. 0, interlock always ON; 1, DI1 determine the interlock status ; 2, AI1 determine the interlock status, the range of AI1 must be ON/OFF; 3, AI2 determine the interlock status, the range of AI2 must be ON/OFF; 4, TIMER OR, the output OR with the period timer; 5, TIMER AND, the output AND with the period timer.
286	1	Interlock for output1
287	1	Interlock for output2
288	1	Interlock for output3
289	1	Interlock for output4
290	1	Interlock for output5
291	1	Interlock for output6
292	1	Interlock for output7
293	1	Setpoint increment on the display each time the user hits the up/down buttons. Units are 0.1Deg, 10 = 1Deg and so on.
294	2	Last key pressed counter. Minutes since the used last pressed a key.
295	1	Freeze protect setpoint. If the ambient temperature less than the setpoint, the heating valve will open some time the Delay to off register set .
296	1	Delay to open. The heating valve will open if the ambient temp less than the Freeze temp setpoint last the time this register set. The units is second.
297	1	Delay to close. The duration the heating valve open. The units is minute.
298	1	Analog input1 function selection. 0, normal; 1, freeze protect sensor input; 2, occupancy sensor input; 3, sweep off mode; 4, clock mode; 5, change over mode. Refer to d11 on page13.
299	1	Analog input2 function selection. 0, normal; 1, freeze protect sensor input; 2, occupancy sensor input; 3, sweep off mode; 4, clock mode; 5, change over mode. Refer to d11 on page13.
300	1	d11 – Digital input 1 function. Refer to d11 description in Table 1: Advanced Menu Items
301	2	Period timer ON time.
302	2	Period timer OFF time.
303	1	Period timer units. 0, second; 1, minute; 2, hour.
304	1	Keypad encoded value. Last keypress, READ ONLY
305	1	LED hundred's digit, , can drive the LEDs manually when the display register 203 is set to manual (5)
306	1	LED ten's digit code, can drive the LEDs manually when the display register 203 is set to manual (5)
307	1	LED one's digit code, can drive the LEDs manually when the display register 203 is set to manual (5)
308	1	LED discrete status symbols, can drive the LEDs manually when the display register 203 is set to manual (5)
309	1	Input auto/ manual enable. Bit0 correspond to analog input1(register 180); bit1 to analog input2(register 181); bit2 to digital input1(register 311). 0, auto mode, the corresponding input value from sensor; 1, manual mode, the corresponding value from serial port.
310	1	Output auto/manual enable. Bit 0 to 4 correspond to output1 to output5, bit 5 correspond to output6(register 102), bit 6 correspond to output7(register 103). 0, auto mode; 1, manual mode.
311	1	Digital manual input. Write the manual value for digital input when digital input in manual mode.
312	1	(REV35_0) DEADMASTER_AUTO_MANUAL = 0, the default, outputs will not change, stay in whatever mode they were last commanded; DEADMASTER_AUTO_MANUAL = 1, the output will be trigger to "AUTO" mode; DEADMASTER_AUTO_MANUAL = 2, the outputs will go to manual on or off as defined in register 313.
313	1	REV 35_0 (relay1-5) output manual value when DEADMASTER_AUTO_MANUAL = 2; register 313, Bit0 is for relay 1, bit1 for relay 2 and so on up to output 5
314	1	REV 35_0 (analog output - cooling)deadmaster config value during deadmaster be triggered when DEADMASTER_AUTO_MANUAL = 2; Value Range: 0 to 1000
315	1	REV 35_0 (analog output - heating)deadmaster config value during deadmaster be triggered when DEADMASTER_AUTO_MANUAL = 2 Value Range: 0 to 1000
316	1	RESERVE

Address	Bytes	Register and Description
317	1	Dead master. The Tstat will go to occupied mode automatically if there is no serial communications for a user defined period of time, for example if the register is set to 10 the thermostat will go to occupied mode if there are no communications for a period of 10 minutes. Set the register to 0 to disable the feature
318	1	Rounding display. 0 = round the display to the nearest digit; 1 = round the display to the nearest 1/10 unit; 5 = round the display to the nearest 1/2 unit. 2,3,4 reserved.
319	1	The minimum address which the device can accept, use this to limit addresses to a certain defined band.
320	1	The maximum device address can be set. The device address should be between min and max address, default is 254
321	1	Rotation features [Old disabled feature] Output 2 is controlled by which output table in the rotation group. READ ONLY.
322	1	Rotation feature, [disabled]: output3
323	1	Rotation feature, [disabled]: output4
324	1	Rotation feature, [disabled]: output5
325	1	Rotation time left. Long long time left the rotation will happen. READ ONLY.
326	1	Show the size of E2 chip. 0 = 24c02, 1 = 24c08/24c16.
327	1	Assign the timer to be used for which feature. 0 = period timer, 1 = rotation timer, 2 = interlock, 3 = PWM timer.
328	1	The output1 function, there are three functions for the output1.0 = normal ON/OFF output, 1 = rotation (old disabled feature) 2 = lighting control where one button can be assigned to toggle a relay on & off
329	1	Rotation Feature: Show which output table is used for output1 when output1 belongs to the rotation group
330	1	Rotation Feature: Show which output table is used for output1 when output2 belongs to the rotation group
331	1	Rotation Feature: Show which output table is used for output1 when output3 belongs to the rotation group
332	1	Rotation Feature: Show which output table is used for output1 when output4 belongs to the rotation group
333	2	How much time left before output rotation gets retriggered
334	1	The output2 function setting: 0 = normal ON/OFF output, 1 = rotation, 2 = lighting control.
335	1	Output3 function setting (see above)
336	1	Output4 function setting (see above)
337	1	Output5 function setting (see above)
338	1	Default occupied setpoint. Works in concert with the "occupied setpoint control register", register 339
339	1	Occupied Setpoint Control Register: 0 = normal, setpoint is managed by the serial port and keypad, the stat will remember the last occupied setpoint and use that during the next occupied period. 1 = Default mode, the last occupied setpoint if forgotten and the occupied setpoint gets reset to the default. 2 = trigger an event, when a master controller writes 2 to this register, the default setpoint will be copied to the occupied setpoint after which the Tstat will set the value back to 1 to show the event has been serviced.
340	1	Enable/disable PIR correspond 1/0 respectively.
341	2	Reserved
342	2	Reserved
343	2	Reserved
344	2	Reserved
345	2	Reserved
346	2	Reserved
347	2	Reserved
348	1	Time format. 0 = 12hours, 1 = 24hours
349	1	Clock, year
350	1	Clock, month
351	1	Clock, week
352	1	Clock, day
353	1	clock, hours
354	1	clock, minutes
355	1	clock, seconds
356	1	alarm, not used now
357	1	work day, wake time hour
358	1	work day, wake time minutes

Address	Bytes	Register and Description
359	1	work day, away time, hour
360	1	work day, away time, minute
361	1	work day, home time, hour
362	1	work day, home time, minute
363	1	work day, sleep time, hour
364	1	work day, sleep time, minute
365	1	weekend day, wake time, hour
366	1	weekend day, wake time, minutes
367	1	weekend, away time, hour
368	1	weekend, away time, minute
369	1	weekend, home time, hour
370	1	weekend, home time, minute
371	1	weekend, sleep time, hour
372	1	weekend, sleep time, minute
373	1	reserved
374	1	reserved
375	1	reserved
376	1	reserved
377	1	reserved
378	1	reserved
379	2	cooling setpoint ,middle setpoint + cooling deadband
380	2	middle setpoint, normal setpoint , same with register 135,but two byte and resoluition l s0.1 degree
381	1	LCD turn off, 0 = turn off, 1 = normal
382	1	The first two bytes on line1 of LCD, user information
383	1	The second two bytes on line1 of LCD, user information
384	1	The throrrd two bytes on line1 of LCD, user information
385	1	The fourth two bytes on line1 of LCD, user information
386	1	The first two bytes on line2 of LCD, user information
387	1	The second two bytes on line2 of LCD, user information
388	1	The thirtdwo bytes on line2 of LCD, user information
389	1	The fourth two bytes on line2 of LCD, user information
390	2	The first two character on LCD for internal sensor user name,
391	2	The second two character on LCD for internal sensor user name,
392	2	The third two character on LCD for internal sensor user name,
393	2	The fourth two character on LCD for internal sensor user name,
394	2	The first two character on LCD for input1 sensor user name,
395	2	The second two character on LCD for input1 sensor user name,
396	2	The third two character on LCD for input1 sensor user name,
397	2	The fourth two character on LCD for input1 sensor user name,
398	2	The first two character on LCD for input2 sensor user name,
399	2	The second two character on LCD for input2 sensor user name,
400	2	The third two character on LCD for input2 sensor user name,
401	2	The fourth two character on LCD for input2 sensor user name,
402	2	The first two character on LCD for input3 sensor user name,
403	2	The second two character on LCD for input3 sensor user name,
404	2	The third two character on LCD for input3 sensor user name,

Address	Bytes	Register and Description
405	2	The fourth two character on LCD for input3 sensor user name,
406	2	The first two character on LCD for input4 sensor user name,
407	2	The second two character on LCD for input4 sensor user name,
408	2	The third two character on LCD for input4 sensor user name,
409	2	The fourth two character on LCD for input4 sensor user name,
410	2	The first two character on LCD for input5 sensor user name,
411	2	The second two character on LCD for input5 sensor user name,
412	2	The third two character on LCD for input5 sensor user name,
413	2	The fourth two character on LCD for input5 sensor user name,
414	2	The first two character on LCD for input6 sensor user name,
415	2	The second two character on LCD for input6 sensor user name,
416	2	The third two character on LCD for input6 sensor user name,
417	2	The fourth two character on LCD for input6 sensor user name,
418	2	The first two character on LCD for input7 sensor user name,
419	2	The second two character on LCD for input7 sensor user name,
420	2	The third two character on LCD for input7 sensor user name,
421	2	The fourth two character on LCD for input7 sensor user name,
422	2	The first two character on LCD for input8 sensor user name,
423	2	The second two character on LCD for input8 sensor user name,
424	2	The third two character on LCD for input8 sensor user name,
425	2	The fourth two character on LCD for input8 sensor user name,
426	2	The first two character on LCD for output1 user name,
427	2	The second two character on LCD for output1 user name,
428	2	The third two character on LCD for output1 user name,
429	2	The fourth two character on LCD for output1 user name,
430	2	The first two character on LCD for output2 user name,
431	2	The second two character on LCD for output2 user name,
432	2	The third two character on LCD for output2 user name,
433	2	The fourth two character on LCD for output2 user name,
434	2	The first two character on LCD for output3 user name,
435	2	The second two character on LCD for output3 user name,
436	2	The third two character on LCD for output3 user name,
437	2	The fourth two character on LCD for output3 user name,
438	2	The first two character on LCD for output4 user name,
439	2	The second two character on LCD for output4 user name,
440	2	The third two character on LCD for output4 user name,
441	2	The fourth two character on LCD for output4 user name,
442	2	The first two character on LCD for output5 user name,
443	2	The second two character on LCD for output5 user name,
444	2	The third two character on LCD for output5 user name,
445	2	The fourth two character on LCD for output5 user name,
446	2	The first two character on LCD for output6 user name,
447	2	The second two character on LCD for output6 user name,
448	2	The third two character on LCD for output6 user name,
449	2	The fourth two character on LCD for output6 user name,
450	2	The first two character on LCD for output7 user name,

Address	Bytes	Register and Description
451	2	The second two character on LCD for output7 user name,
452	2	The third two character on LCD for output7 user name,
453	2	The fourth two character on LCD for output7 user name,
454	1	daysetpoint option,0 = office, 1 = hotel mode
455	1	coasting configure for PWM output
456	1	cooling1 configure for PWM output
457	1	cooling2 configure for PWM output
458	1	cooling3 configure for PWM output
459	1	heating1 configure for PWM output
460	1	heating2 configure for PWM output
461	1	heating3 configure for PWM output
462	1	current output for first PWM output
463	1	current output for second PWM output
464	1	free cool cobfigure byte
465	1	analog output in OFF table, coating mode
466	1	analog output in OFF table, cooling1 mode
467	1	analog output in OFF table, cooling2 mode
468	1	analog output in OFF table, cooling3 mode
469	1	analog output in OFF table, heating1 mode
470	1	analog output in OFF table, heating2 mode
471	1	analog output in OFF table, heating3 mode
472	1	lock register
473	1	ANALOG INPUT RANGE. 0 = raw data, 1 = thermistor, 2 = %, 3 = ON/OFF, 4 = N/A, 5 = OFF/ON
474	1	ANALOG INPUT RANGE. 0 = raw data, 1 = thermistor, 2 = %, 3 = ON/OFF, 4 = N/A, 5 = OFF/ON
475	1	ANALOG INPUT RANGE. 0 = raw data, 1 = thermistor, 2 = %, 3 = ON/OFF, 4 = N/A, 5 = OFF/ON
476	1	ANALOG INPUT RANGE. 0 = raw data, 1 = thermistor, 2 = %, 3 = ON/OFF, 4 = N/A, 5 = OFF/ON
477	1	ANALOG INPUT RANGE. 0 = raw data, 1 = thermistor, 2 = %, 3 = ON/OFF, 4 = N/A, 5 = OFF/ON
478	1	ANALOG INPUT RANGE. 0 = raw data, 1 = thermistor, 2 = %, 3 = ON/OFF, 4 = N/A, 5 = OFF/ON
479	1	ANALOG INPUT RANGE. 0 = raw data, 1 = thermistor, 2 = %, 3 = ON/OFF, 4 = N/A, 5 = OFF/ON
480	1	ANALOG INPUT RANGE. 0 = raw data, 1 = thermistor, 2 = %, 3 = ON/OFF, 4 = N/A, 5 = OFF/ON
481	1	Analog input1 value
482	1	Analog input2 value
483	1	Analog input3 value
484	1	Analog input4 value
485	1	Analog input5 value
486	1	Analog input6 value
487	1	Analog input7 value
488	1	Analog input8 value
489	2	Calibration for analog input1
490	2	Calibration for analog input2
491	2	Calibration for analog input3
492	2	Calibration for analog input4
493	2	Calibration for analog input5
494	2	Calibration for analog input6
495	2	Calibration for analog input7
496	2	Calibration for analog input8

Address	Bytes	Register and Description
497	1	LCD screen1,select which information will display on LCD
498	1	LCD screen2,select which information will display on LCD
499	1	sun icon contro
500	1	moon icon control
501	1	heat cool
502	1	current ON to OFF delay for output 1
503	1	current ON to OFF delay for output 2
504	1	current ON to OFF delay for output 3
505	1	current ON to OFF delay for output 4
506	1	current ON to OFF delay for output 5
507	1	current OFF to ON delay for output 1
508	1	current OFF to ON delay for output 2
509	1	current OFF to ON delay for output 3
510	1	current OFF to ON delay for output 4
511	1	current OFF to ON delay for output 5
512	1	RS485 mode
513	1	current setpoint
514	1	current setpoint offset for free cool feature
515	1	PIC version of Humidity module
516	2	Humidity value
517	2	Current humidity sensor value
518	1	Update calibration data, when set to 1, tstat will update the calibration data to PIC
519	1	Calibration points number, value can be single or two point calibration for the Tstat6
520	1	Decide which calibration table will be used. 0 = default table 1 = customer table
521	1	Reserve for factory test
522	1	Reserve for factory test
523	2	1st calibration capacitance value
524	2	1st calibration humidity value
525	2	2nd calibration capacitance value
526	2	2nd calibration humidity value
527	2	Reserve for 3rd calibration capacitance value (future)
528	2	Reserve for 3rd calibration humidity value (future)
529	2	Reserve for 4th calibration capacitance value (future)
530	2	Reserve for 4th calibration humidity value (future)
531	2	Reserve for 5th calibration capacitance value (future)
532	2	Reserve for 5th calibration humidity value (future)
533	2	Reserve for 6th calibration capacitance value (future)
534	2	Reserve for 6th calibration humidity value (future)
535	2	Reserve for 7th calibration capacitance value (future)
536	2	Reserve for 7th calibration humidity value (future)
537	2	Reserve for 8th calibration capacitance value (future)
538	2	Reserve for 8th calibration humidity value (future)
539	2	Reserve for 9th calibration capacitance value (future)
540	2	Reserve for 9th calibration humidity value (future)
541	2	Reserve for 10th calibration capacitance value (future)
542	2	Reserve for 10th calibration humidity value (future)